

LM2685

Dual Output Regulated Switched Capacitor Voltage Converter

General Description

The LM2685 CMOS charge-pump voltage converter operates as an input voltage doubler, +5V regulator and inverter for an input voltage in the range of +2.85V to +6.5V. Five low cost capacitors are used in this circuit to provide up to 50mA of output current at +5V ($\pm 5\%$), and 15mA at -5V. The LM2685 operates at a 130 kHz switching frequency to reduce output resistance and voltage ripple. With an operating current of only 800 μ A (operating efficiency greater than 80% with most loads) and 6 μ A typical shutdown current, the LM2685 is ideal for use in battery powered systems. The device is in a small 14-pin TSSOP package.

- TSSOP-14 package
- 80% typical conversion efficiency at 25mA
- Input voltage range of 2.85V to 6.5V
- Independent shutdown control pins

Applications

- Cellular phones
- Pagers
- PDAs
- Handheld instrumentation
- 3.3V to 5V voltage conversion applications

Features

- +5V regulated output
- Inverts $V_{OS}(+5V)$ to $V_{NEG}(-5V)$
- Doubles input supply voltage

Typical Application and Connection Diagram

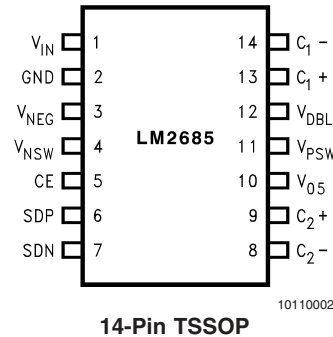
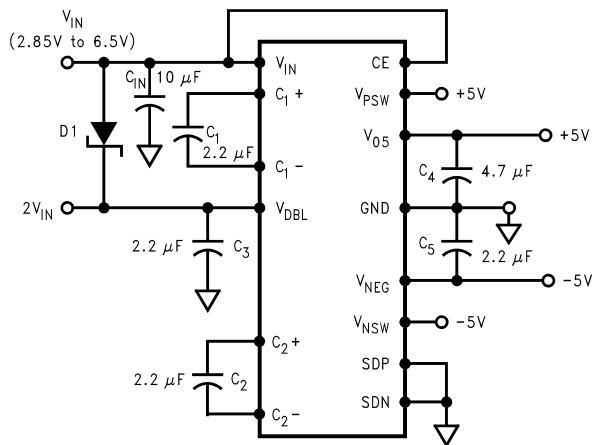

10110001

Ordering Information

Order Number	Package Type	NSC Package Drawing	Supplied As
LM2685MTC	TSSOP-14	MTC14	94 Units, Rail
LM2685MTCX	TSSOP-14	MTC14	2.5k Units, Tape and Reel

Pin Description

Pin No.	Name	Function
1	V_{IN}	Power supply input voltage.
2	GND	Power supply ground.
3	V_{NEG}	Negative output voltage created by inverting V_{05} .
4	V_{NSW}	V_{NEG} output connected through a series switch, NSW.
5	CE	Chip enable input. This pin is high for normal operation and low for shutdown. (See Shutdown and Load Disconnect section in the Detailed Device Description division).
6	SDP	Positive side shutdown input. This pin is low for normal operation and high for positive side shutdown and V_{PSW} load disconnect. (See Shutdown and Load Disconnect section in the Detailed Device Description division).
7	SDN	Negative side shutdown input. This pin is low for normal operation and high for negative side shutdown and V_{NSW} load disconnect. (See Shutdown and Load Disconnect section in the Detailed Device Description division).
8	C_2^-	The negative terminal of inverting charge-pump capacitor, C2.
9	C_2^+	The positive terminal of inverting charge-pump capacitor, C2.
10	V_{05}	Regulated +5V output.
11	V_{PSW}	V_{05} output connected through a series switch, PSW.
12	V_{DBL}	Voltage Doubler Output. ($2.85V \leq V_{IN} \leq 5.4V$. See Voltage Doubler section).
13	C_1^+	The positive terminal of doubling charge-pump capacitor, C1.
14	C_1^-	The negative terminal of doubling charge-pump capacitor, C1.

Absolute Maximum Ratings (Note 1)

If Military/Aerospace specified devices are required, please contact the National Semiconductor Sales Office/Distributors for availability and specifications.

Supply Voltage (V_{IN} to GND or GND to V_{NEG})	6.8V
SDN, SDP, CE	(GND – 0.3V) to ($V_{IN} + 0.3V$)
V_{O5} Continuous Output Current	80mA
V_{O5} Short-Circuit Duration to GND (Note 2)	Indefinite

Continuous Power Dissipation ($T_A = 25^\circ\text{C}$) (Note 3)	600mW
T_{JMAX} (Note 3)	150°C
θ_{JA} (Note 3)	140°C/W
Operating Ambient Temp. Range	-40°C to 85°C
Operating Junction Temp. Range	-40°C to 125°C
Storage Temp. Range	-65°C to 150°C
Lead Temp. (Soldering, 10 sec.)	300°C
ESD Rating (Note 4)	2kV

Electrical Characteristics

Limits with standard typeface apply for $T_J = 25^\circ\text{C}$, and limits in **boldface type** apply over the full temperature range. Unless otherwise specified $V_{IN} = 3.6V$, $C_1 = C_2 = C_3 = C_5 = 2.2\mu\text{F}$, $C_4 = 4.7\mu\text{F}$ (Note 5)

Symbol	Parameter	Conditions	Min	Typ	Max	Units
V^+	Supply Voltage		2.85		6.5	V
I_Q	Supply Current	No Load		800	1600	μA
		No Load, $V_{IN} = 6.5V$		300	600	
I_{SD}	Shutdown Supply Current	$V_{IN} = 6.5V$		6	30	μA
V_{SD}	Shutdown Pin Input Voltage for CE, SDP, SDN	Logic Input High @ 6.5V	2.4			V
		Logic Input Low @ 6.5V			0.8	
$I_L (+5V)$	Output Current at V_{O5}	$2.85V < V_{IN} < 6.5V$			50	mA
$R_O (-5V)$	Output Resistance at V_{NEG}	$I_L = 15\text{mA}$ (Note 6)		20	40	Ω
F_{SW}	Switch Frequency		85	130	180	kHz
P_{EFF}	Average Power Efficiency at V_{O5}	$2.85V \leq V_{IN} \leq 6.5V$ $I_L = 25\text{mA}$ to GND		82		%
V_{O5}	Output Regulation	$1\text{mA} < I_L < 50\text{mA}$, $V_{IN} = 6.5V$ (Note 7)	4.848	5.05	5.252	V
		$1\text{mA} < I_L < 50\text{mA}$, $V_{IN} = 6.5V$ (Note 7)	4.797	5.05	5.303	
G_{LINE}	Line Regulation	$2.85V < V_{IN} < 3.6V$		0.25		%V
		$3.6V < V_{IN} < 6.5V$		0.05		
G_{LOAD}	Load Regulation	$1\text{mA} < I_L < 50\text{mA}$, $V_{IN} = 6.5V$		0.3	1.0	%
R_{SW}	Series Switch Resistance V_{NEG} to V_{NSW}	$V_{IN} > 2.85V$		1.5		Ω
	V_{O5} to V_{PSW}			5.0		

Note 1: Absolute Maximum Ratings indicate limits beyond which damage to the device may occur. Operating Ratings indicate conditions for which the device is intended to be functional, but do not guarantee specific performance limits. For guaranteed specifications and test conditions, see the Electrical Characteristics.

Note 2: V_{O5} may be shorted to GND without damage. However, shorting V_{NEG} to V_{O5} may damage the device and must be avoided. Also, for temperature above 85°C, V_{O5} must not be shorted to GND or device may be damaged.

Note 3: The maximum allowable power dissipation is calculated by using $P_{DMAX} = (T_{JMAX} - T_A)/\theta_{JA}$, where T_{JMAX} is the maximum junction temperature, T_A is the ambient temperature and θ_{JA} is the junction-to-ambient thermal resistance of the specified package.

Note 4: The human body model is a 100 pF capacitor discharged through a 1.5k Ω resistor into each pin.

Note 5: In the typical operating circuit, capacitors C_1 and C_2 are 2.2 μF , 0.3 Ω maximum ESR capacitors. Capacitors with higher ESR will increase output resistance, reduce output voltage and efficiency.

Note 6: Specified output resistance includes internal switch resistance and ESR of capacitors. See the Detailed Device Description section.

Note 7: The 50 mA maximum current assumes no current is drawn from V_{DBL} pin. See Voltage Doubler section in the Detailed Device Description.

Typical Performance Characteristics

Unless otherwise specified, $T_A = 25^\circ\text{C}$, $V_{IN} = 3.6\text{V}$.

Supply Current vs Input Voltage

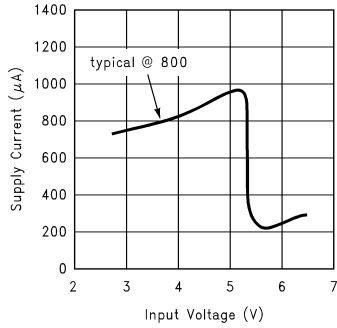

10110006

Supply Current vs Temperature

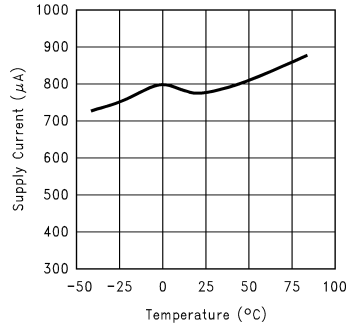

10110007

Efficiency vs Load Current

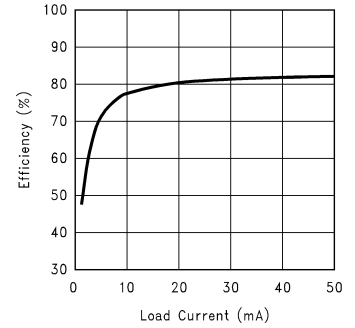

10110008

Output Voltage (V_{O5}) vs. Load Current

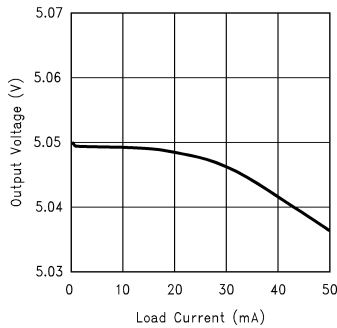

10110009

V_{O5} Voltage vs. Input Voltage

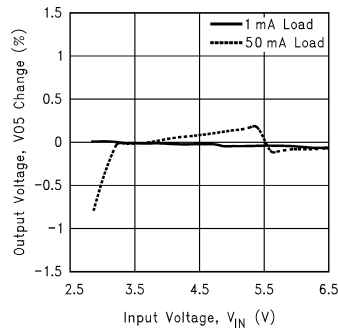

10110021

Output Resistance (V_{NEG}) vs. Temperature

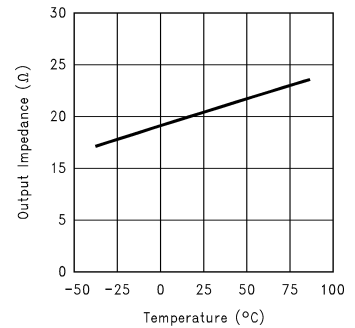

10110010

Output Resistance (V_{DBL}) vs. Input Voltage

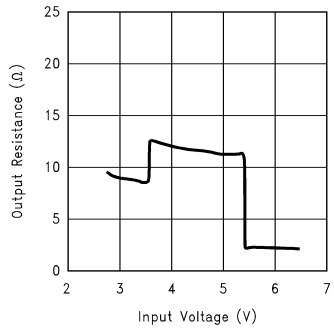

10110011

Output Resistance (V_{DBL}) vs. Temperature

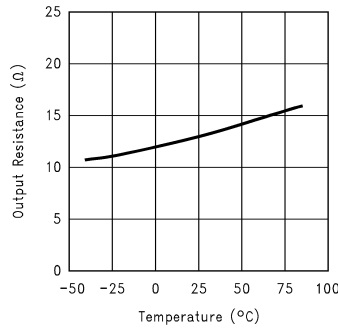

10110012

Switch Frequency vs. Temperature

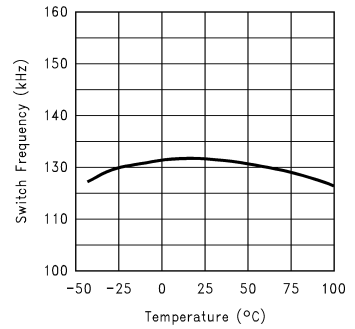

10110013

Typical Performance Characteristics Unless otherwise specified, $T_A = 25^\circ\text{C}$, $V_{IN} = 3.6\text{V}$. (Continued)

Line Transient Response (with 5mA Load)

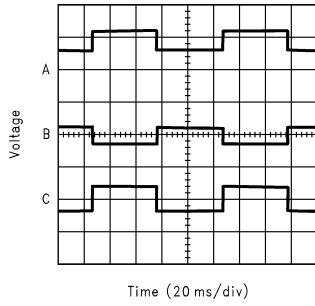

10110014

A: INPUT VOLTAGE: $V_{IN} = 3.2\text{V}$ to 6.0V , 5V/div
 B: OUTPUT VOLTAGE: $V_{PSW} = 100\text{mV/div}$
 C: OUTPUT VOLTAGE: $V_{NSW} = 100\text{mV/div}$

V_{O5} Load Transient Response

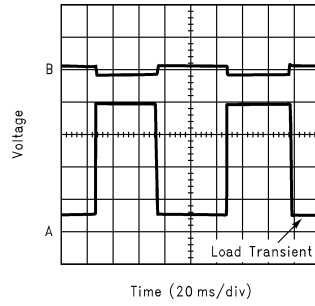

10110015

A: LOAD CURRENT: $I_{LOAD} = 5\text{mA}$ to 39.6mA , 10mA/div
 B: OUTPUT VOLTAGE: $V_{O5} = 10\text{mV/div}$

V_{NSW} Load Transient Response

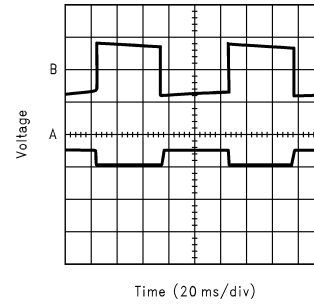

10110016

A: LOAD CURRENT: $I_{LOAD} = 4.4\text{mA}$ to -9.4mA , 10mA/div
 B: OUTPUT VOLTAGE: $V_{NSW} = 50\text{mV/div}$

V_{PSW} and V_{NSW} Response to CE (with 5mA Load)

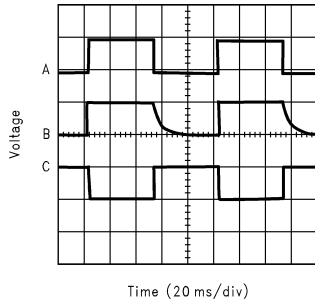

10110017

A: CE INPUT: 5V/div
 B: OUTPUT VOLTAGE: $V_{PSW} = 5\text{V/div}$
 C: OUTPUT VOLTAGE: $V_{NSW} = 5\text{V/div}$

V_{O5} Response to SDP (with 5mA Load)

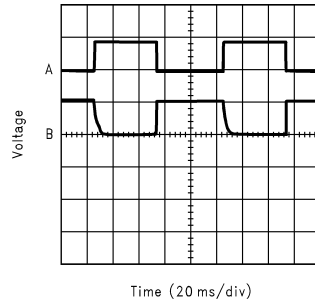

10110018

A: SDP INPUT: 5V/div
 B: OUTPUT VOLTAGE: 5V/div

V_{NSW} Response to SDP (with 5mA Load)

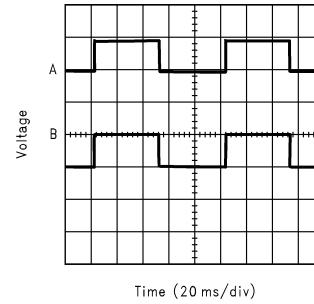

10110019

A: SDP INPUT: 5V/div
 B: OUTPUT VOLTAGE (V_{NSW}): 5V/div

V_{NSW} Response to SDN (with 5mA Load)

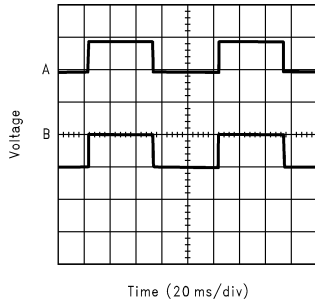

10110020

A: SDN INPUT: 5V/div
 B: OUTPUT VOLTAGE (V_{NSW}): 5V/div

Detailed Device Description

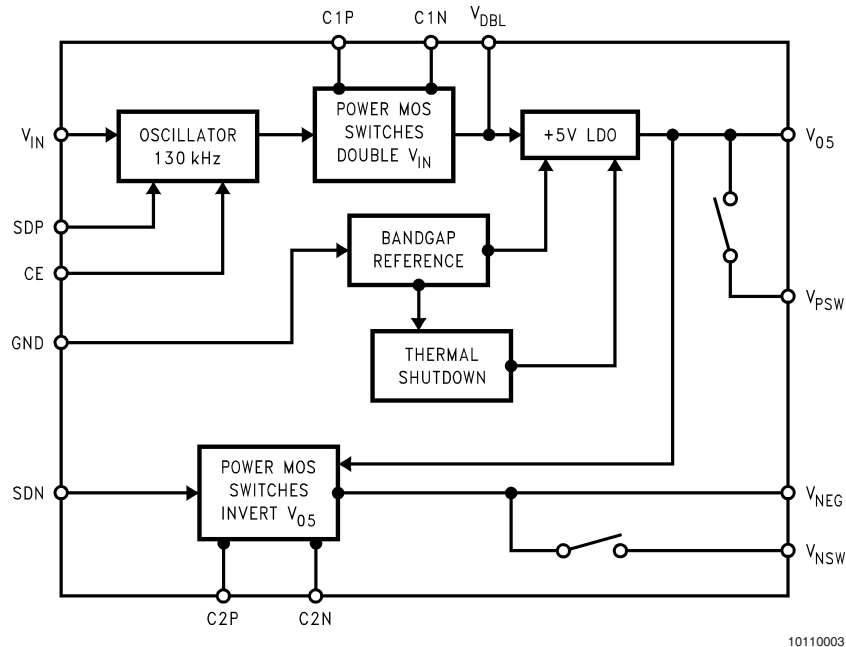

FIGURE 1. Functional Block Diagram

The LM2685 CMOS charge pump voltage converter operates as an input voltage doubler, +5V regulator and inverter for an input voltage in the range of +2.85V to +6.5V. It delivers maximum load currents of 50mA and 15mA for the regulated +5V and the inverted output voltages respectively, with an operating current of only 800 μ A. It also has a typical shutdown current of 6 μ A. All these performance qualities make the LM2685 an ideal device for battery powered systems.

The LM2685 has three main functional blocks: a voltage doubler, a low dropout (LDO) regulator, and a voltage inverter. Figure 1 shows the LM2685 functional block diagram.

VOLTAGE DOUBLER

The voltage doubler stage doubles the input voltage V_{IN} , within the range of +2.85V to +5.4V. For V_{IN} above 5.4V, the doubler shuts off and the input voltage is passed directly to V_{DBL} via an internal power switch.

The doubler contains four large CMOS switches which are switched in a sequence to double the input supply voltage. Figure 2 illustrates the voltage conversion scheme. When S2 and S4 are closed, C1 charges to the supply voltage V_{IN} . During this time interval, switches S1 and S3 are open. In the next time interval, S2 and S4 are opened at the same time, S1 and S3 are closed, the sum of the input voltage V_{IN} and the voltage across C1 gives the $2V_{IN}$ and the voltage across C2 gives the $2V_{IN}$ at V_{DBL} output. V_{DBL} supplies the LDO regulator. It is recommended not to load V_{DBL} when V_{05} has a load of 50mA. For proper operation, the sum of V_{DBL} and V_{05} loads must not be more than 50mA.

The Schottky diode D1 is only needed for start-up. The internal oscillator circuit uses the V_{DBL} and GND pins. The voltage across them must be larger than 1.8V to ensure the operation of the oscillator. During start-up, D1 is used to charge up the voltage at V_{DBL} pin to start the oscillator; it

also protects the device from turning on its own parasitic diode and potentially latching up. The diode should have enough current carrying capability to charge capacitor C3 at start-up, as well as a low forward voltage to prevent the internal parasitic diode from turning on. A Schottky diode like 1N5817 can be used for most applications. If the input ramp is less than 10V/ms, a smaller schottky diode like MBR0520LT1 can be used to reduce the circuit size.

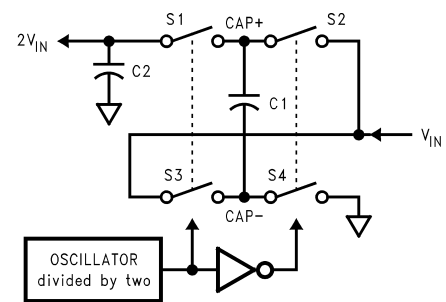

FIGURE 2. Voltage Doubler Principle

+5 LDO REGULATOR

V_{DBL} is the input to an LDO regulator that regulates it to a +5 output voltage at V_{05} . V_{PSW} is tied to V_{05} through a series switch PSW. The LDO output capacitor (4.7 μ F Tantalum) may be tied to either V_{05} or V_{PSW} .

INVERTER

From the V_{05} output, a -5V output is created at V_{NEG} by means of an inverting charge pump. This negative output is unregulated, meaning that its output will droop as the load current at V_{NEG} increases. The inverter contains four large

Detailed Device Description

(Continued)

CMOS switches which are in a sequence to invert the input supply voltage. *Figure 3* illustrates the voltage conversion scheme. When S1 and S3 are closed, C1 charges to the supply voltage V_{O5} . During this time interval, switches S2 and S4 are open. In the second time interval, S1 and S3 are open; at the same time, S2 and S4 are closed, C1 is charging C2. After a number of cycles, the voltage across C2 will be pumped to V_{O5} . Since the anode of C2 is connected to ground, the output at the cathode of C2 equals $-(V_{O5})$ when there is no load current. The output voltage drop when a load is added is determined by the parasitic resistance ($R_{ds(on)}$) of the MOSFET switches and the ESR of the capacitors) and the charge transfer loss between capacitors.

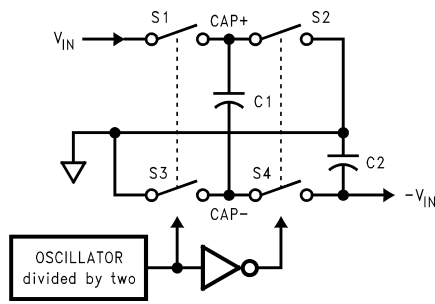

FIGURE 3. Voltage Inverter Principle

SHUTDOWN AND LOAD DISCONNECT

In addition to the nominal charge pump and regulator functions, the LM2685 features shutdown and load disconnect circuitry. CE (chip enable) and SDP (shutdown positive) perform the same task with opposite polarities. When CE is low or SDP is high, all circuit blocks are disabled and V_{O5} falls to ground potential. This is the same result as when the die temperature exceeds 150°C (typical), and the device's internal thermal shutdown is triggered.

Forcing SDN (shutdown negative) high disables only the inverting charge pump. The doubling charge pump and the LDO regulator continue to operate, so the V_{O5} and the V_{PSW} remain at 5V.

The LM2685 incorporates two low impedance switches tied to the V_{O5} and V_{NEG} outputs, because some special applications require load disconnect and this is achievable via the switches. Switch PSW connects V_{O5} to V_{PSW} , and switch NSW connects V_{NEG} to V_{NSW} . In normal operation, these switches are closed, allowing 5V loads to be tied to either V_{O5} or V_{PSW} and -5V loads to be tied to either V_{NEG} or V_{NSW} . Driving SDN high opens switch NSW only, while forcing CE low or SDP high, opens both the PSW and NSW.

Application Information

CAPACITOR SELECTION

The output resistance and ripple voltage are dependent on the capacitance and ESR values of the external capacitors.

VOLTAGE DOUBLER EXTERNAL CAPACITORS

The selection of capacitors are based on the specifications of the dropout voltage (which equals $I_{OUT} R_{OUT}$), the output voltage ripple, and the converter efficiency.

$$R_{OUT} = 2 R_{SW} + \frac{2}{f_{OSC} \times C_1} + 4 ESR_{C_1} + ESR_{C_3}$$

where R_{SW} is the sum of the ON resistance of the internal MOSFET switches as shown in *Figure 2*.

The peak-to-peak output voltage ripple is determined by the oscillator frequency, the capacitance and ESR of the capacitor C3.

$$V_{RIPPLE} = \frac{I_L}{f_{OSC} \times C_2} + 2 \times I_L \times ESR_{C_3}$$

High capacitance (2.2μF to higher), low ESR capacitors can reduce the output resistance and the voltage ripple.

$$\text{Power efficiency of} = \frac{P_{OUT}}{P_{IN}} = \frac{I_L^2 R_L}{I_L^2 R_L + I_L^2 R_{OUT} + I_Q (V+)}$$

where $I_Q(V+)$ is the quiescent power loss of the IC device, and $I_L^2 R_L$ is the conversion loss associated with the switch on-resistance, the two external capacitors and their ESRs.

Low ESR capacitors (table to be referenced) are recommended to maximize efficiency, reduce the output voltage drop and voltage ripple.

+5 LDO REGULATOR EXTERNAL CAPACITORS

The voltage doubler output capacitor, C3, serves as the input capacitor of the +5 LDO regulator. The output capacitor C4, must meet the requirement for minimum amount of capacitance and appropriate ESR (Equivalent Serving Resistance) for proper operation. The ESR value must remain within the regions of stability as shown in *Figure 4*, *Figure 5* and *Figure 6* to ensure output's stability. A minimum capacitance of 1μF is required at the output. This can be increased without limit, but a 4.7μF tantalum capacitor is recommended for loads ranging up to the maximum specification. With lighter loads of less or equal to 10mA, ceramic capacitor of at least 1μF and ESR in the milliohms can be used. This has to be connected to V_{PSW} pin instead of the V_{O5} pin.

Any output capacitor used should have a good tolerance over temperature for capacitance and ESR values. The larger the capacitor, with ESR within the stable region, the better the stability and noise performance.

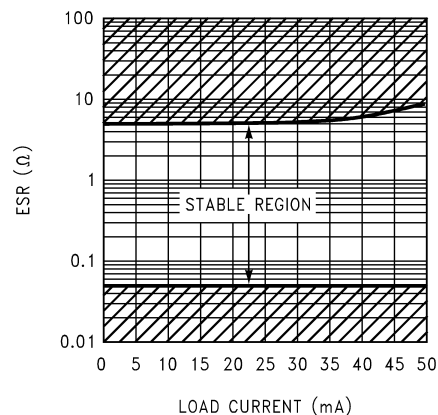

FIGURE 4. ESR Curve for $C_{OUT} = 2.2\mu F$

Application Information (Continued)

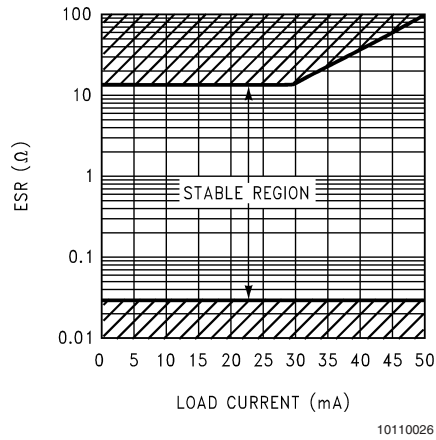

FIGURE 5. ESR Curve for $C_{OUT} = 4.7\mu\text{F}$

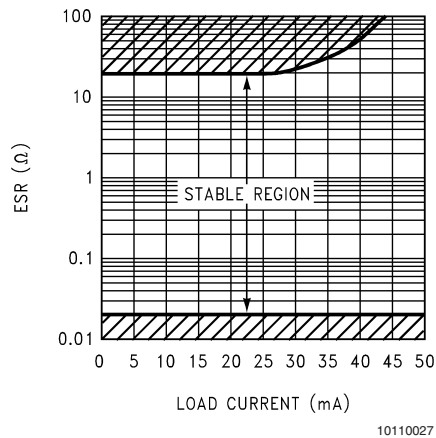
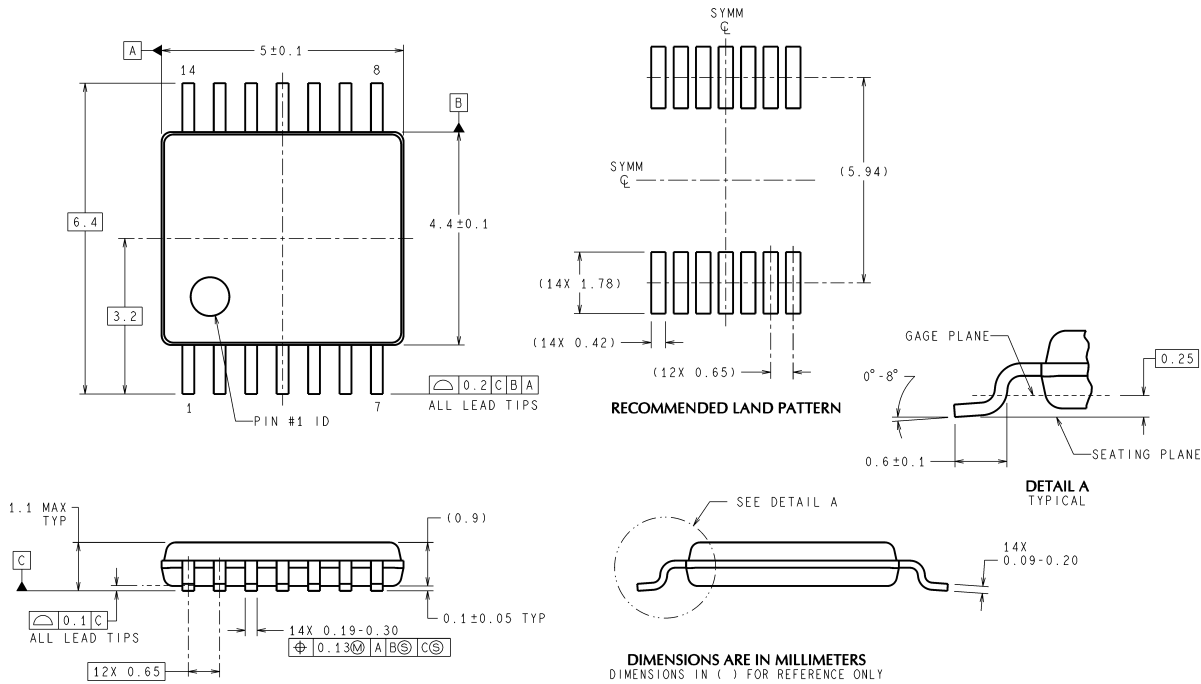

FIGURE 6. ESR Curve for $C_{OUT} = 10\mu\text{F}$

INVERTER EXTERNAL CAPACITORS

As discussed in the +5 LDO Regulator External Capacitors section, the output resistance and ripple voltage are dependent on the capacitance and ESR values of the external capacitors. A minimum of $1\mu\text{F}$ capacitor with good tolerance over temperature for capacitance and ESR values. The capacitance value can be increased without limit while still maintain high low ESR value. $2.2\mu\text{F}$ capacitors are recommended for the two external capacitors, C_2 and C_5 of the inverter.

Physical Dimensions inches (millimeters) unless otherwise noted



MTC14 (Rev D)

TSSOP-14 Package
14-Lead Thin Shrink Small-Outline Package
For Ordering, Refer to Ordering Information Table
NS Package Number MTC14

National does not assume any responsibility for use of any circuitry described, no circuit patent licenses are implied and National reserves the right at any time without notice to change said circuitry and specifications.

For the most current product information visit us at www.national.com.

LIFE SUPPORT POLICY

NATIONAL'S PRODUCTS ARE NOT AUTHORIZED FOR USE AS CRITICAL COMPONENTS IN LIFE SUPPORT DEVICES OR SYSTEMS WITHOUT THE EXPRESS WRITTEN APPROVAL OF THE PRESIDENT AND GENERAL COUNSEL OF NATIONAL SEMICONDUCTOR CORPORATION. As used herein:

1. Life support devices or systems are devices or systems which, (a) are intended for surgical implant into the body, or (b) support or sustain life, and whose failure to perform when properly used in accordance with instructions for use provided in the labeling, can be reasonably expected to result in a significant injury to the user.
2. A critical component is any component of a life support device or system whose failure to perform can be reasonably expected to cause the failure of the life support device or system, or to affect its safety or effectiveness.

BANNED SUBSTANCE COMPLIANCE

National Semiconductor certifies that the products and packing materials meet the provisions of the Customer Products Stewardship Specification (CSP-9-111C2) and the Banned Substances and Materials of Interest Specification (CSP-9-111S2) and contain no "Banned Substances" as defined in CSP-9-111S2.



National Semiconductor
Americas Customer
Support Center
 Email: new.feedback@nsc.com
 Tel: 1-800-272-9959

National Semiconductor
Europe Customer Support Center
 Fax: +49 (0) 180-530 85 86
 Email: europa.support@nsc.com
 Deutsch Tel: +49 (0) 69 9508 6208
 English Tel: +44 (0) 870 24 0 2171
 Français Tel: +33 (0) 1 41 91 8790

National Semiconductor
Asia Pacific Customer
Support Center
 Email: ap.support@nsc.com

National Semiconductor
Japan Customer Support Center
 Fax: 81-3-5639-7507
 Email: jpn.feedback@nsc.com
 Tel: 81-3-5639-7560

www.national.com